

5166



Ciena's 5166 Router is purpose-built for 5G networks that converge 4G/5G fronthaul, midhaul, and backhaul (xHaul) networks onto a common, simpler infrastructure. With dense 1/10/25GbE to 100/200/400GbE aggregation and support for both hard network slicing (FlexEthernet) and soft network slicing (Segment Routing), the 5166 is the ideal platform to simplify and de-risk the unique 4G to 5G journeys of mobile and wholesale operators.

The industry drives toward converged xHaul transport networks

Continued annual growth in 4G and 5G Radio Access Network (RAN) bandwidth demand is driving a change in the mix of connections and services, from 1GbE aggregation to 10GbE, and 10/25GbE aggregation to 100/200/400GbE. This ongoing growth will continue as network operators, mobile, and wholesalers embark on their unique 4G to 5G journeys—resulting in substantial upgrades to their xHaul networks—while traditional Mobile Network Operators (MNOs) modernize their transport networks to support the vastly improved end-to-end performance that is the promise of 5G. One key aspect of 5G networks, besides the substantial improvements in capacity and latency, is the decoupling of the Remote Radio Unit (RRU), also referred to as Remote Radio Head (RRH), from the Baseband Unit (BBU) in a mobile macro cell. This results in a fronthaul transport network between the RRU and the centralized BBUs that will then be virtualized, using Commercial Off-The-Shelf (COTS) servers. This new architecture is referred to as Centralized/Cloud (C-RAN). The BBU itself will be further disaggregated into a Centralized Unit (CU) and Distributed Unit (DU), which results in a midhaul transport network between them. By converging 4G/5G fronthaul, 5G midhaul, and 4G/5G backhaul, network infrastructure cost and complexity are optimized.

C-RAN enables significant reductions in power consumption, footprint, and complexity deployed at 4G/5G cell sites. The Common Public Radio Interface (CPRI) for 4G LTE C-RAN is highly inefficient from a fronthaul bandwidth perspective. For 5G NR RAN, available capacity will be significantly higher than 4G LTE, particularly

Features and Benefits

- Temperature-hardened (-40°C to +65°C) for temperature-challenged or space-constrained locations
- 32 x 1/10/25GbE and 2 x 100/200/400GbE fixed ports
- L1/L2/L3 low latency switching
- Service isolation using FlexEthernet (FlexE)
- Carrier Ethernet, IP routing, SR-MPLS, and SRv6 ready
- Hardware-assisted routing and switching OAM scaled to deliver 25GbE services with guaranteed SLA differentiation
- Secure Zero-Touch Provisioning (SZTP) for rapid, secure, and error-free turn-up of services
- Advanced synchronization, including built-in GNSS receiver
- Built-in RFC 2544 and ITU-T Y.1564 SAT with 100 Gb/s traffic generation and analysis
- SDN-ready next-generation management including support for protocols such as NETCONF/YANG and gNMI/gRPC
- Ciena's MCP multi-layer support for end-to-end network management control and planning
- Redundant AC or DC power

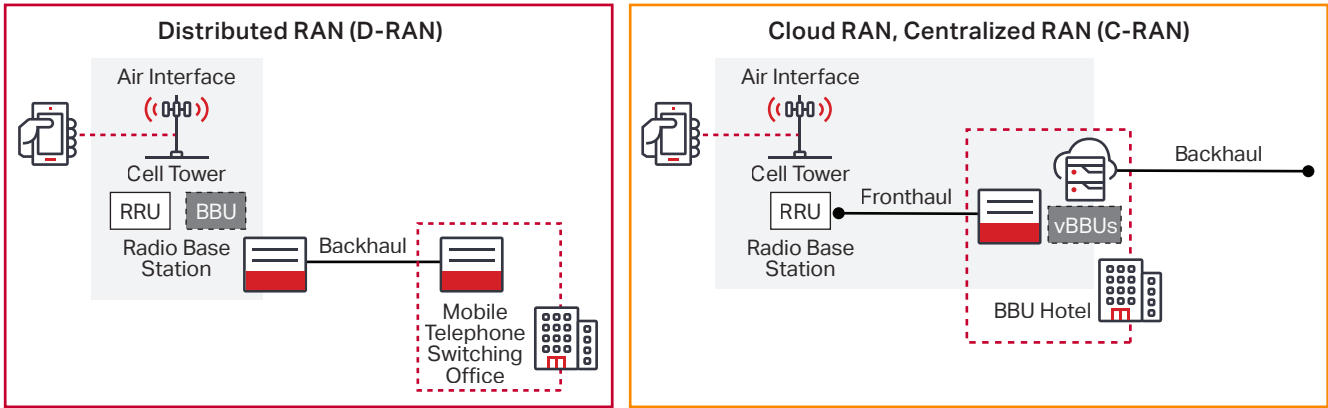

Figure 2. 5G NR RAN architecture

with High Order Multiple-Input Multiple-Output (MIMO) antenna deployments. Several sub-layers of the 5G NR RAN functions will be decomposed and virtualized over x86 COTS servers, which will have a major impact on the required xHaul network performance to deliver upon the full promise of 5G.

5G NR RAN

As MNOs upgrade to a 5G NR RAN network, shown in Figure 2, changes in the User Equipment (UE, more commonly referred to as a mobile smartphone or handset), RAN, and mobile core are required. 5G brings the need to deliver higher capacity over the mobile network, driving the change in mix of wireline technology, performance, and services required in the access network from 1GbE to 10GbE, and increasingly from 10GbE to 25GbE—all requiring aggregation up to 100GbE, 200GbE, or 400GbE. Additionally, the need to reduce latency for new applications like Augmented Reality (AR), Virtual Reality (VR), mobile gaming, and the growing IoT space will require Ultra-Reliable Low-Latency Communications (URLLC) and Network Slicing capabilities.

All of these new technology and associated performance requirements, and support for existing 4G RAN networks as well, are supported by Ciena's 5166 Router.

Dense, compact form-factor platform

Efficient use of real estate assets is a growing concern for MNOs, who either host their own network equipment or lease power, space, and connectivity from wholesale providers. As services multiply, MNOs must choose between stacking 10G xHaul-capable equipment and new 5G NR RAN equipment, which will incur additional collocation costs. The 5166's sleek, shallow depth and front access enable and facilitate cabinet and controlled environmental vault deployment. Extended temperature range support allows for installations in uncontrolled environments for outdoor aggregation of 1/10/25GbE, enabling high capacity at the outdoor edge for both 4G and 5G connectivity.

Space is increasingly limited and expensive, and network operators face substantial capital expenditures to activate new locations or must retire active equipment to free space for new service delivery. Addressing bandwidth demand growth by deploying more and larger equipment is simply not a sustainable business model—economically or environmentally. Ciena's 5166 cost-effectively offers dense 25GbE service delivery in a 1RU fixed form-factor with dual power supplies to minimize network downtime and a variety of pluggable optics offering greater flexibility.

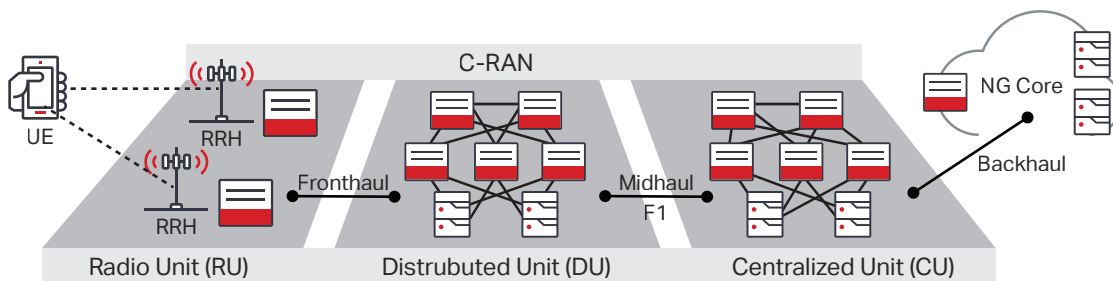

Figure 2. 5G NR RAN architecture

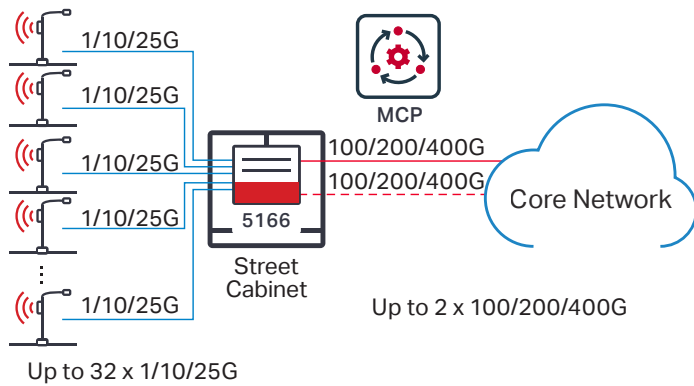

Figure 3. 5166 Router outside service and aggregation

Fine-grained SLA monitoring and enforcement

The 5166 includes performance benchmark testing based on ITU-T Y.1564 and RFC 2544, enabling end-to-end 1/10/25G line-rate traffic measurements across virtual circuits. This approach improves end-customer satisfaction by enabling operations personnel to proactively respond to network events via increased performance visibility for differentiated Service Level Agreement (SLA) reporting.

Programmable midhaul gateway

As MNOs look for the ability to derive new revenue streams, the 5166 eCPRI/Ethernet-capable interfaces can be used to provide guaranteed SLA-based 5G services, made possible by network slicing and the underlying programmable wireline infrastructure that supports it, for new use cases and revenues—which is different from existing best-effort 4G LTE-centric mobile network services.

FlexE can mitigate latency impacts in the midhaul when utilizing from a midhaul gateway or transparently transporting traffic from a fronthaul gateway. FlexE, standardized in the

OIF, supports channelization as one of its use cases. Figure 4 shows how multiple traffic types (eCPRI, RoE, wireline services) can be carried using FlexE channels over a 100Gb/s FlexE link. The 5166 optimizes bandwidth and provides deterministic low-latency transport with FlexE. By mapping traffic into one of these channels with dedicated TDM-like scheduling, its latency and jitter will not be impacted by traffic in the other channel and bounded low-latency delivery can be ensured.

Advanced multi-layer protocol support

The 5166 supports a flexible selection of service offerings, including L2 and L3 services over a carrier-class, connection-oriented infrastructure using MPLS and Segment Routing.

The platform supports a rich suite of L2/L3 features with Ethernet, MPLS, MPLS LDP, Seamless MPLS, Operations, Administration, and Maintenance (OAM), QoS, Sync, LAG, FRR, TI-LFA, FlexEthernet, Network Slicing, IGP (IS-IS, OSPF), BGP/MP-BGP, Segment Routing functionality. Security functions and North Bound (NB) interfaces like ACL, TACACS+, Radius, streaming telemetry, NETCONF and YANG are also supported.

The 5166 operates as a full-featured IP router supporting NETCONF/YANG to easily integrate into an open SDN environment with full visibility via streaming telemetry, and automated provisioning using open APIs.

Synchronization and timing

To realize the full benefit of 5G, highly accurate time/phase synchronization, frequency synchronization, and even more stringent timing precision will be required. In the more latency-sensitive fronthaul network, care must be taken to deliver the required performance, especially in situations where traffic from 4G and 5G RRH is mixed. As eCPRI was defined to utilize

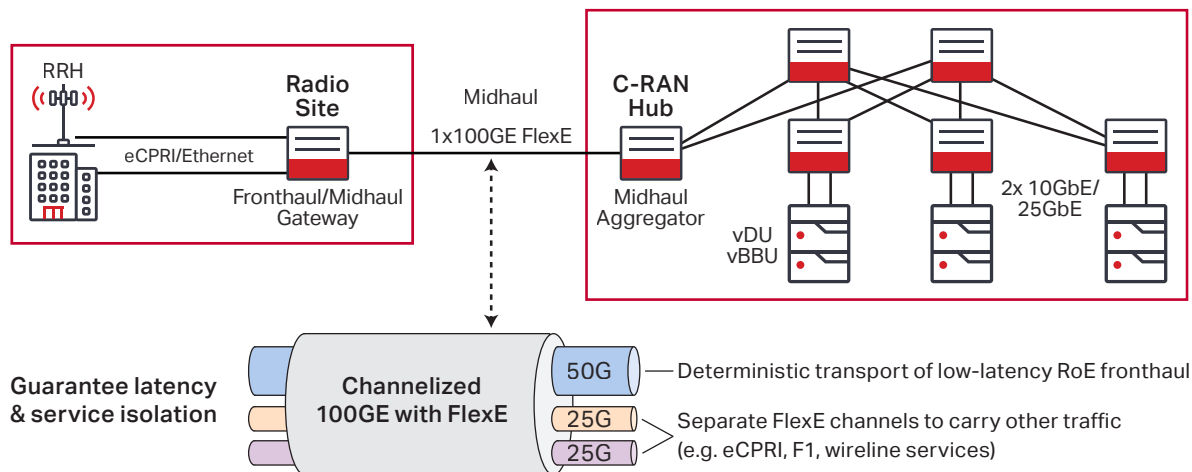

Figure 4. 5166 Channelized FlexE

a native transport, it is somewhat more tolerant to jitter than CPRI, which is natively a time domain-oriented constant bitstream. New technologies, such as FlexE and Time Sensitive Networking (TSN), have emerged as tools to provide these latency and jitter guarantees.

The 5166's rich timing and synchronization options, including support for IEEE 1588v2 and Global Navigation Satellite System (GNSS) receivers, enable new capabilities. These include Sync-as-a-Service with SLA for wholesale providers, hard and soft Network Slicing, as well as additional applications like massive Machine-Type Communications (mMTC), URLLC, and native Ethernet services in the wireless domain via 5G NRs.

The cost-effectiveness and versatility of the 5166 router provides synchronization and timing for C-RAN architectures with support for eCPRI, Ethernet, Adaptive IP™, and high density 1/10/25GbE to 100/200/400GbE aggregation.

Differentiation through accelerated service velocity

Service velocity has become a critical competitive advantage for network operators, mobile, and wholesalers. In many cases, service velocity is the determining factor in winning new service opportunities. The 5166 implements Ciena's unique SZTP capabilities, allowing operators to deploy new services rapidly and securely in a fully automated manner. By reducing or eliminating costly and time-consuming manual intervention, provisioning errors are eliminated via SZTP. Most importantly, SZTP improves service deployment velocity and significant competitive advantage.

Rich routing and switching OAM suite of capabilities

As network operators and their customers increasingly rely on new IP/MPLS networks, providers must maintain guaranteed service levels. Networks must support a broad array of routing and switching OAM capabilities to ensure operators can proactively and reactively maintain and report on the ongoing health of their networks and delivered services. 5166 also supports a comprehensive set of hardware-assisted routing and switching OAM capabilities, and is architected to provide SLA metrics and OAM at a high scale. This enables operators to take full advantage of the port density and 800 Gb/s fabric for delivering the maximum number of services at the lowest cost. Additionally, the 5166 has an embedded line-rate Service Activation Test (SAT) engine (RFC 2544, ITU-T Y.1564), with traffic generation to a full 100 Gb/s to guarantee strict, market-differentiating SLAs, without relying on costly external test equipment and the highly trained personnel that requires.

Simplified multi-layer management and control

Ciena's Manage, Control and Plan (MCP) domain controller software offers a unique and comprehensive solution for the administration of mission-critical networks that span access, metro, and core domains, and provides unprecedented multi-layer visibility from the photonic to the routing and switching layers. With this innovative management approach, MCP supports a programmable and automatable solution that provides a fully open approach to installing, manipulating, and monitoring service behaviors in an SDN environment.

Technical Information

Interfaces

Ethernet Ports

- 32 x 1GbE/10GbE/25GbE SFP28 ports
- 2 x 100GbE/200GbE/400GbE QSFP-DD ports
 - OIF FlexEthernet (FlexE) Implementation Agreement v1.1 and v2.0
- PON SFP+ Support

Other

- 1 x USB-C Off-switch memory
- 1 x USB-C Console
- 1 x RJ45 Time-of-Day (ToD + 1PPS in/out)
- 1 x SMB Phase input (1 pps or 10MHz in/out)
- 1 x SMB GNSS antenna
- 1 x RJ45 Management (MGMT)

Ethernet

- IEEE 802.1D MAC Bridges
- IEEE 802.1p Class of Service (CoS) prioritization
- IEEE 802.1Q VLANs
- IEEE 802.1ad Provider Bridging (Q-in-Q) VLAN full S-VLAN range
- VLAN tunneling (Q-in-Q) for Transparent LAN Services (TLS)
- Layer 2 Control Frame Tunneling
- IEEE 802.1ax Link Aggregation (LAG): Active/Active; Active/ Standby
- IEEE 802.3ad Link Aggregation Control Protocol (LACP)
- Jumbo frames up to 9216 bytes
- IEEE 802.3-2018 IEEE Standard for Ethernet and supporting following rates
 - IEEE 802.3z-1998 Gigabit Ethernet
 - IEEE 802.3ab-1999 1000Base-T via copper SFP
 - IEEE 802.3ae-2002 10Gb/s
 - IEEE 802.3ba-2010 100Gb/s
 - IEEE 802.3by-2016 25Gb/s
 - IEEE 802.3bs-2017 200Gb/s and 400Gb/s

Carrier Ethernet OAM

- EVC Ping (IPv4)
- IEEE 802.1ab-2006 Link Layer Discovery Protocol (LLDP)
- IEEE 802.1ag-2007 Connectivity Fault Management (CFM)
- IEEE 802.3ah-2004 EFM Link-fault OAM
- ITU-T Y.1731 Performance Monitoring

Synchronization

- External Timing Interfaces
 - ITU-T G.703 Frequency in or out (2.048 MHz, and 10 MHz)
 - ITU-T G.703 1pps and ToD in or out
- Integrated GNSS receiver
- ITU-T G.8262/G.8264 EEC option1 and option2

*Future: 2H21

- ITU-T G.8275.1 full timing support T-GM, T-BC and T-TSC
- G.8273.2 clock, Class C
- G.8275.2 Telecom Profile*
- Stratum 3E oscillator

Networking Protocols

- ISO10598 IS-IS intra-domain routing protocol
- OSFP Segment Routing extension
- OSFP TI-LFA Topology Independent Fast Reroute using Segment Routing
- RFC1195 Use of OSI Is-Is for Routing in TCP/IP and Dual Environments
- RFC1997 BGP Community Attribute
- RFC2328 OSPF Version 2
- RFC3630 Traffic Engineering (TE) extensions to OSPF Version 2
- RFC4577 OSPF as the Provider/Customer Edge Protocol for BGP/MPLS IP Virtual Private Networks
- BGP Prefix Independent Convergence
- EVPN FXC draft-ietf-bess-evpn-vpwsfxc-03.txt
- RFC2698 A Two Rate Three Color Marker
- RFC2865 Remote Authentication Dial in User Service (RADIUS)
- RFC3031 Multiprotocol Label Switching Architecture
- RFC3032 MPLS label stack encoding
- RFC6478 Pseudowire Status for Static Pseudowires
- RFC7769 Media Access Control (MAC) Address Withdrawal over Static Pseudowire
- RFC4762 : Virtual Private LAN Service (VPLS) Using Label Distribution Protocol (LDP) Signaling (HVPLS)
- Hierarchical VPLS (H-VPLS)
- RFC6073 : Segmented Pseudowire
- RFC4664 Framework of L2VPN (VPLS/VPWS)
- RFC5654 MPLS-Transport Profile (TP)
- RFC3107 Support BGP carry Label for MPLS
- RFC4271 A Border Gateway Protocol 4 (BGP-4)
- RFC4360 BGP Extended Communities Attribute
- RFC4364 BGP/MPLS IP Virtual Private Networks (VPNs)
- RFC4456 BGP Route Reflection: An Alternative to Full Mesh Internal BGP (IBGP)
- RFC4632 Classless Inter-domain Routing (CIDR): The Internet Address Assignment and Aggregation Plan
- RFC4760 Multiprotocol Extensions for BGP-4
- RFC4762 Virtual Private LAN Service (VPLS) Using Label Distribution Protocol (LDP) Signaling (HVPLS)
- RFC5004 Avoid BGP Best Path Transitions from One External to Another

- RFC5036 LDP Specification
- RFC5037 Experience with the LDP protocol
- RFC5301 Dynamic Hostname Exchange Mechanism for IS-IS
- RFC5302 Domain-Wide Prefix Distribution with Two-Level IS-IS
- RFC5303 Three-Way Handshake for IS-IS Point-to-Point Adjacencies
- RFC5309 Point-to-Point Operation over LAN in Link State Routing Protocols
- RFC5396 Textual Representation of Autonomous Systems (AS) Numbers
- RFC5398 Autonomous System (AS) Number Reservation for Documentation Use
- RFC5492 Capabilities Advertise with BGP-4
- RFC5561 LDP Capabilities
- RFC5668 4-Octet AS Specific BGP Extended Community
- RFC6241 Network Configuration Protocol (NETCONF)
- RFC6310 Pseudowire (PW) Operations, Administration, and Maintenance (OAM) Message Mapping
- RFC6793 BGP Support for Four-Octet Autonomous System (AS) Number Space
- RFC7432 EVPN VPWS/VPLS
- RFC7737 Label Switched Route (LSP) Ping and Traceroute Reply Mode Simplification
- RFC4448 Encapsulation Methods for Transport of Ethernet over MPLS Networks (PW over MPLS)
- RFC4665 Service Requirement of L2 VPN
- RFC6391 Flow-Aware Transport of Pseudowires over an MPLS Packet Switched Network
- RFC8469 Ethernet Control Word
- RFC8029: Detecting Multiprotocol Label Switched (MPLS) Data-Plane Failures
- RFC8287: Label Switched Path (LSP) Ping/Traceroute for Segment Routing (SR)
- RFC6426: MPLS On-Demand Connectivity Verification and Route Tracing
- RFC7911 Advertisement of Multiple Paths in BGP
- RFC8214 Virtual Private Wire Service Support in Ethernet VPN
- SR-MPLS TI-LFA Topology Independent Fast Reroute using Segment Routing draftietf-rtgwg-segment-routing-ti-lfa-03
- RFC5880 Bidirectional Forwarding Detection (BFD)
- RFC5881 Bidirectional Forwarding Detection (BFD) for IPv4 and IPv6 (Single Hop)
- RFC5883 Bidirectional Forwarding Detection (BFD) for Multihop Paths
- RFC5884 Bidirectional Forwarding Detection (BFD) for MPLS Label Switched Paths (LSPs)

Technical Information continued

Network Management

- Alarm Management and Monitoring Configuration
- Event and Alarm Notification/Generation Comprehensive Management
 - Via CLI Management
 - Via Netconf/YANG Models
- gRPC-based Streaming telemetry
- IPv4 and IPv6 Management Support
- IPv4 Management ACL (in-band)
- IPv6 Management ACL (in-band)
- RADIUS, AAA
- RFC2131 DHCP Client
- RFC3315 DHCPv6 Client
- RFC6614 RadSec Client
- RFC5425 Syslog over TLS
- SNMPv2 Trap
- SNMPv2 GET
- RFC 3046 DHCP Relay
- RFC 5905 NTP Client
- Secure File Transfer Protocol (SFTP)
- Secure Shell (SSHv2)
- RFC8572 Secure Zero-Touch Provisioning (SZTP)
- Software upgrade via FTP, SFTP
- Syslog Accounting
- TACACS + AAA
- Web GUI

Physical Characteristics

Dimensions

- 17.36"(W) x 9.96"(D) x 1.73"(H)
- 441 mm (W) x 253 mm (D) x 44 mm (H)
- ETSI EN 300 132-2
- ETSI EN 300 132-3

Weight

- AC variant: 11.2 lbs; 5.2 kg
- DC variant: 11.2 lbs; 5.2 kg

Power

- DC input: -48 Vdc (nominal)
- AC input: 100 Vac, 240 Vac (nominal)

Standards Compliance

Emissions and Immunity

- CISPR 24 Class A
- CISPR 32 Class A
- CISPR 35 Class A
- ETSI EN 300 386
- ETSI EN 301 489-1
- ETSI EN 301 489-19
- ETSI EN 303 413
- ETSI EN 55032
- ETSI EN 55035
- GR-1089 Issue 6
- FCC Part 15 Subpart B, Class A
- Industry Canada ICES-003 Class A
- VCCI Class A

NEBS (Network Equipment-Building System)

- LEVEL 3 certification
- GR-63 Issue 5

Safety

- ANSI/UL 60950-1 2nd edition / ETSI EN 60950-1, A1:2011 and A2:2014
- CAN/CSA-C22.2 No. 60950-1, Amd 1:2011, Amd 2:2014
- EN 62368-1:2014+A11:2017 and
- CSA/UL 62368-1:2014
- IEC 60825-1
- IEC 60825-2

Environmental

- ETSI EN 300-019-2-1
- ETSI EN 300-019-2-2
- ETSI EN 300-119-3
- GR-3108 Class 2 / ETSI EN 300-019-3-3 Class 3.2
- NEBS Level 3 CO (GR-63 Core)
- RoHS2 Directive (2011/65/EU)
- WEEE 2012/19/EU

Operating Temperature

- -40°F to +149°F (-40°C to +65°C)

Storage Temperature

- -40°F to +158°F (-40°C to +70°C)

Humidity

- Non-condensing 5% to 90%

Service Security

- Broadcast Containment Egress Port Restriction
- Hardware-based DOS Attack Prevention Layer 2, 3, 4 Protocol Filtering
- User Access Rights Local user authorization

Visit the Ciena Community
Answer your questions



Ordering information

Part Number	Product Description
170-5166-900	5166, (32) 25/10/1GE SFP28, (2)400G/200/100GE QSFP-DD, EXT. TEMP, DUAL DC POWER
170-5166-901	5166, (32) 25/10/1GE SFP28, (2)400G/200/100GE QSFP-DD, EXT. TEMP, DUAL AC POWER
Required OS Base System Perpetual Software Licenses	
S75-LIC-5166EO-P	SAOS BASE OS, ETHERNET & OAM, FLEXE, 100G & 200G SOFTWARE LICENSE FOR 5166, PERPETUAL
Optional OS Applications	
S75-LIC-5166MPLS-P	SAOS ROUTING AND MPLS SOFTWARE LICENSE FOR 5166, PERPETUAL
S75-LIC-5166SYNC-P	SAOS SYNCHRONIZATION SOFTWARE LICENSE FOR 5166, PERPETUAL
S75-LIC-5166SEC-P	SAOS SECURITY SOFTWARE LICENSE FOR 5166, PERPETUAL
S75-LIC-5166400GS-P	SAOS 400G SOFTWARE LICENSE FOR 5166, PERPETUAL